

## B.Tech. IV Semester (Main/Back) Examination 2012

## Mechanical Engineering

## 4ME5 Kinematics of Machines

Time : 3 Hours

Maximum Marks : 80

Min. Passing Marks : 24

**Instructions to Candidates:**

Attempt any **Five questions** selecting **one question** from **each unit**. All questions carry **equal marks**. (Schematic diagrams must be shown wherever necessary. Any data you feel missing may suitably be assumed and stated clearly.) Units of quantities used/ calculated must be stated clearly.

Use of following Support material is permitted during examination. (Mentioned in form No.205)

1. Quarter Drawing sheet

**Unit - I**

1. a) With the help of neat sketch, explain 'Tchbeicheff' straight line mechanism. 6
- b) In the slider crank mechanism shown in fig.1, block P reciprocates along the fixed line AB and the crank has a uniform speed of 230 r.p.m., Determine for the

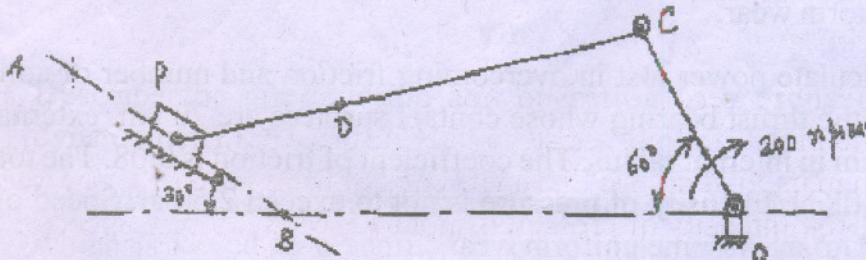

OC = 15cm, PD = 17cm, DC = 30cm, OB = 45cm, given configuration, the velocity and acceleration of the block P and the point D. 10

**Or**

2. a) With the help of neat sketch explain the Klein's construction. 8



- b) Draw and explain the inversions of double slider crank chain. 8

### Unit - II

3. a) What is condition of correct steering? Derive the condition of correct steering for Davis steering mechanism. 8
- b) Calculate the maximum power transmitted by an open belt drive, embracing a pulley by  $120^\circ$ , if the maximum stress in the belt is not to exceed  $140 \text{ N/cm}^2$ . What is the corresponding linear speed of the belt? Particulars of the belt are = width = 10 cm, thickness = 6 mm,  $\rho = 0.97 \text{ gm/cm}^3$ . Assume  $\mu = 0.3$ . 8

Or

4. a) Explain the construction and working of overhead valve mechanism. 8
- b) Derive the condition for maximum power transmitted by belt drive. 8

### Unit - III

5. a) Derive an expression for efficiency of screw jack neglecting collar friction. 8
- b) A car engine has its rated output of 10 KW. Maximum torque developed is 100 N-m. The clutch used is of single plate type, having two active surfaces. Axial pressure is not to exceed 0.85 bar. External diameter of the friction plate is 1.25 times the internal diameter.

Determine the dimension of the friction plate and the axial force exerted by the springs. Assume uniform wear and  $\mu = 0.3$ . 8

Or

6. a) Derive an expression for the torque transmitted by a single plate clutch assuming uniform wear. 8
- b) Calculate power lost in overcoming friction and number of collars required for the thrust bearing whose contact surfaces are 20 cm. external radius and 15cm in internal radius. The coefficient of friction is 0.08. The total axial load is 30KN. Intensity of pressure is not to exceed 2.5 bar. Speed of the shaft is 420 r.p.m. Assume uniform wear. 8

### Unit - IV

7. a) Prove that the ratio of tension on tight side to tension on slack side in case of band and block brake is



$$\frac{T_n}{T_0} = \left( \frac{1 + \mu \tan \theta}{1 - \mu \tan \theta} \right)^n$$

Where  $T_n$  = maximum tension on tight side

$T_0$  = Minimum tension on slack side

$n$  = Number of blocks

$\theta$  = Semi angle subtended by block. 8

- b) A differential band brake as shown in figure 2, has an angle of contact of  $225^\circ$ . The band has a compressed woven lining and bears against a cast iron drum of 350mm diameter. The brake is to sustain a torque of 350N-m and the coefficient of friction between the band and the drum is 0.3. Find = (i)

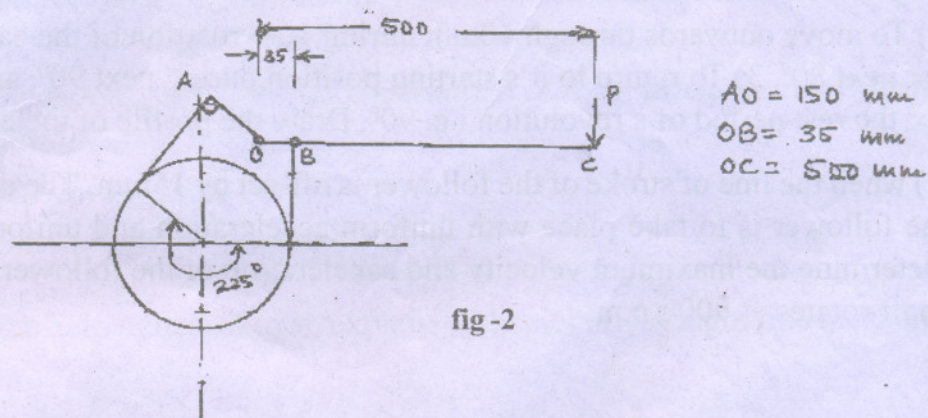

the necessary force (P) for the clockwise and anticlockwise rotation of the drum, and (ii) the value of 'OA' for the brake to be self-locking, when the drum rotates clockwise. 8

Or

8. a) Describe the construction and operation of a Prony brake absorption dynamometer. 8
- b) A band brake acts on the  $3/4$ th of circumference of a drum of 450mm diameter which is keyed to a shaft. The band brake provides a braking torque of 225 N-m. One end of the band is attached to a fulcrum pin of the lever and the other end to a pin 100 mm from the fulcrum. If the operating force is applied at 500 mm from the fulcrum and the coefficient of friction is 0.25. Find the operating force when the drum rotates in the (i) anticlockwise direction and (ii) clockwise direction. 8



## Unit - V

9. A cam is to be designed for a knife-edge follower with the following data.
1. Cam lift = 40mm during  $90^\circ$  of cam rotation with simple harmonic motion.
  2. Dwell for the next  $30^\circ$ .
  3. During the next  $60^\circ$  of cam rotation, the follower returns to its original position with simple harmonic motion.
  4. Dwell during the remaining  $180^\circ$ .

Draw the profile of the cam when the line of stroke of the follower passes through the axis of the cam shaft. 16

Or

10. A cam with minimum radius of 50mm, rotating clockwise at a uniform speed, is required to give a knife edge follower the motion as described below.

1) To move outwards through 40mm during  $100^\circ$  rotation of the cam 2) To dwell for next  $80^\circ$  3) To return to it's starting position during next  $90^\circ$ , and 4) To dwell for the rest period of a revolution i.e.  $90^\circ$ . Draw the profile of the cam

(i) when the line of stroke of the follower is off-set by 15mm. The displacement of the follower is to take place with uniform acceleration and uniform retardation. Determine the maximum velocity and acceleration of the follower when the cam shaft rotates at 900 r.p.m. 16