

3E1492

Roll No. : _____

Total Printed Pages : **3****3E1492****B.Tech. (Sem. III) (Main/Back) Examination, January - 2012
Electronics & Comm.****3EC2 Electronics Devices & Circuits****(Common for Main & Back of 3EC2, 3AI2, 3EI2 & 3BM2)**Time : **3 Hours**][Total Marks : **80**[Min. Passing Marks : **24****Instructions to Candidates :**

Attempt any five questions selecting one question from each unit. All questions carry equal marks. Schematic diagrams must be shown wherever necessary. Any data you feel missing suitably be assumed and stated clearly. Units of quantities used/calculated must be stated clearly.

Use of following supporting material is permitted during examination.
(Mentioned in form No. 205)

1. _____ Nil _____

2. _____ Nil _____

UNIT - I

- 1 (a) Describe the conductivity and mobility for intrinsic semiconductor. 8
- (b) Find the conductivity of intrinsic germanium at 300°K. If donor type impurity is added to the extent of 1 impurity atom in 10^7 germanium atoms, find the conductivity. Give that n_i at 300°K is $2.5 \times 10^{13}/\text{cm}^3$ and μ_n and μ_p is germanium are 3800 and 1800 $\text{cm}^2/\text{v-s}$ respectively. 8

OR

- 1 (a) What is Hall effect, how it is useful for measuring various parameters of semiconductor ? 8
- (b) What do you mean by Fermi level ? Derive the expression for fermi level and sketch the position in case of intrinsic, p-type and n-type semiconductor. 8

3E1492]



1

[Contd...

UNIT - II

- 2 (a) Draw and explain the working of DC inserter circuit. 8
- (b) What do you mean by clipper circuit? The sinusoidal input given to below circuit, what will be the output : Fig. 1 ?

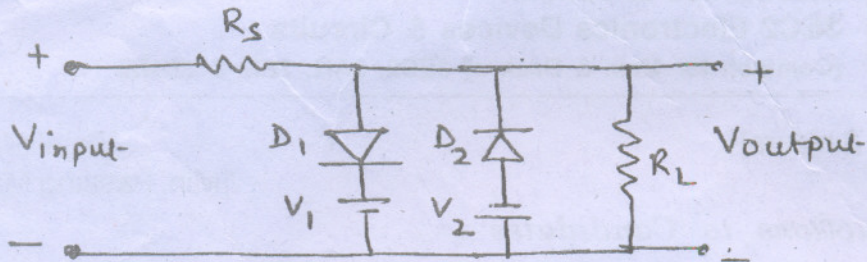

Fig. 1

8

OR

- 2 (a) Describe the importance of load line concept used in electronic circuits. 8
- (b) Explain the effect of negative resistance region in the V-I characteristic of UJT, also gives its applications. 8

8

UNIT - III

- 3 (a) Explain Ebers-Moll model of transistor. 8
- (b) Draw and explain the working of transistor as an amplifier. 8

8

OR

- 3 (a) Write the steps for testing of transistors by digital multimeter
- (i) lead identification (base, collector, emitter)
 - (ii) type of transistor (npn or pnp)
 - (iii) it is good or not.

10

- (b) Write short notes on stabilization techniques for transistor circuit used for different applications.

6



UNIT - IV

- 4 (a) It is required to operate the JFET shown in Fig. 2 at $V_{GS} = -1V$, $V_{DS} = 4V$ and $I_{DS} = 1\text{ mA}$. Determine :
- (i) value of R_D and R_S
 - (ii) voltage gain
 - (iii) Input and output resistance.

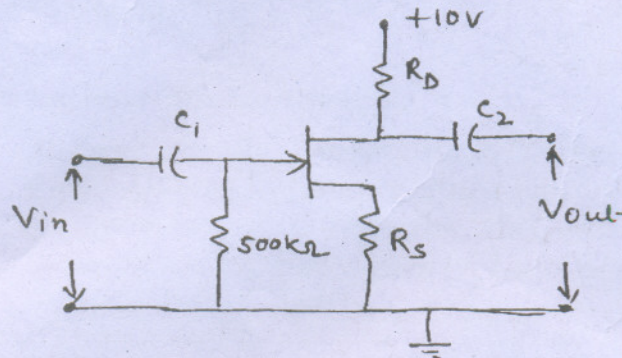

Fig. 2

- (b) Derive various parameters of JFET soft bias configuration useful in using different applications.

OR

- 4 (a) Draw and explain the construction and operation of enhancement MOSFET.
- (b) Write various techniques used for handling MOSFET in laboratory.

UNIT - V

- 5 Write short notes on the following : (any two)
- (a) Role of bootstrapping in darlington pair
 - (b) Emitter follower
 - (c) Cascading transistor amplifiers.

16

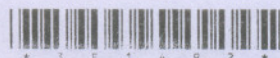

UNIT - II

- 2 (a) Draw and explain the working of DC inserter circuit. 8
- (b) What do you mean by clipper circuit? The sinusoidal input given to below circuit, what will be the output : Fig. 1 ?

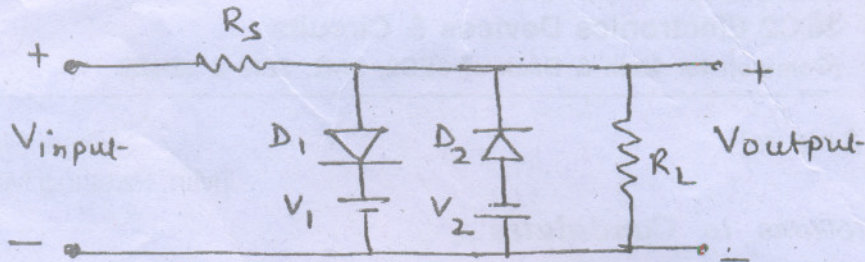

Fig. 1

8

OR

- 2 (a) Describe the importance of load line concept used in electronic circuits. 8
- (b) Explain the effect of negative resistance region in the V-I characteristic of UJT, also gives its applications. 8

8

UNIT - III

- 3 (a) Explain Ebers-Moll model of transistor. 8
- (b) Draw and explain the working of transistor as an amplifier. 8

8

OR

- 3 (a) Write the steps for testing of transistors by digital multimeter
- (i) lead identification (base, collector, emitter)
 - (ii) type of transistor (npn or pnp)
 - (iii) it is good or not.
- 10
- (b) Write short notes on stabilization techniques for transistor circuit used for different applications.

6

